



# TED TODD

FINE WOOD FLOORS

## INSTALLATION GUIDE



*Plank*



*Narrow  
Plank*



*Wide  
Plank*



*Extra-Wide  
Plank*



*Super-Wide  
Plank*



*Herringbone*



*Chevron*



*Chantilly  
panel*



*Parquet de  
Versailles*



*Parquet de  
Chevney*



*Circular  
design panel*



*Parquet de  
Ardeche*



*8 tile  
parquet de  
versailles*



*Shrawley*



*Avery*



*Continuous  
Versailles*



*Wall  
Cladding*

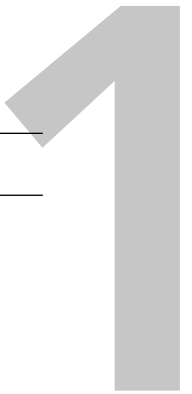

## GUIDELINES FOR: SITE CONDITIONS

Chapter 1 covers the very basic factors that need to be considered for the site of any wood floor installation. Whether the project is a simple renovation of a single room or a whole new building, the same basic rules apply.

This chapter is divided into 3 sections:

- 1A Site planning, Site Environment and Other Trades
- 1B Acclimatisation
- 1C Sub Floor Moisture Testing and Vapour Barriers.

### SITE PLANNING, SITE ENVIRONMENT AND OTHER TRADES

For a successful wood floor installation, getting the site conditions correct is a key element. Good planning from the outset, timing the wood floor installation to be one of the last elements of the fit-out, and care and attention to ensure that the site, sub-floors and services are compatible with the planned installation will go a long way to achieving this.

The following sections offer guidelines to help:

- 1A.1 Contract planning stage, consultation and monitoring.
- 1A.2 Environmental site conditions. (Humidity, temperature)
- 1A.3 Acclimatisation
- 1A.4 Installation of services (water, heating, electrical)
- 1A.5 Physical site conditions, sub-floors and preparedness, cleanliness.
- 1A.6 Other trades.
- 1A.7 Site care of your wood floor, after installation before final handover.
- 1A.8 Summary.
- 1A.9 FAQ's.



Plank



Herringbone



Chevron



Circular design panel



Continuous patterns

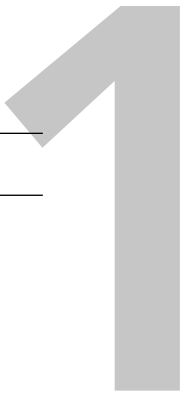

## GUIDELINES FOR: SITE CONDITIONS

### 1A.1 The contract planning stage, consultation and monitoring.

In order for your wood flooring to be correctly installed under appropriate conditions, all parties should have a clear understanding of the requirements of the project (and of the implications for all concerned). To ensure that this is achieved, and for timescales to be met, there should be wide consultation between all parties involved in the project, including sub-contractors and materials suppliers. This consultation should start early in the design stage but is necessary throughout the contract, especially if requirements or the time scale change and as new contract work is initiated. It is important, on a large project, that the timescales for the different elements mesh together and ensure that the wood floor installation is ideally one of the last jobs to be completed.

See BS8201 for full details:

- Section 6- Exchange of information,
- Section 5- Care on site,
- Section 7 – Time schedules.

### 1A.2 Environmental site conditions. (Humidity, temperature)

- Evaluate the jobsite for potential problems before installation begins, and before the wood flooring is delivered.
- Do not deliver wood flooring to the jobsite or install wood flooring until the building is enclosed and the humidity and temperature can be maintained between 16-24°C and 45% to 65% Rh.

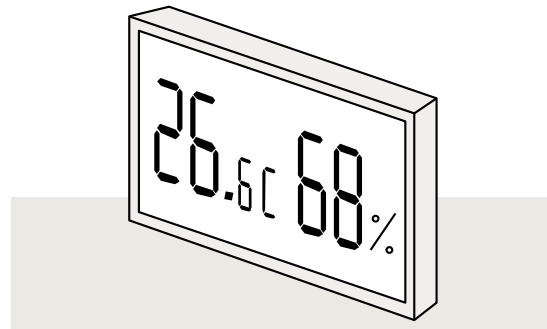

Optimum humidity and temperature should be maintained between 16-24°C and 45% to 65% Rh.

- Do not deliver wood flooring to site until the site is able to accommodate the necessary acclimatisation conditions for the incoming wood flooring. (see section 1.3 below)

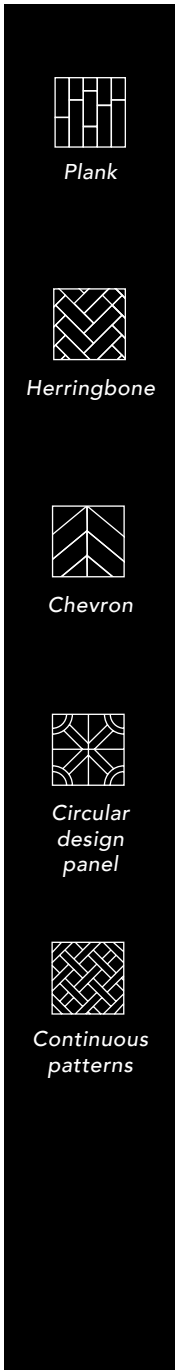



## GUIDELINES FOR: SITE CONDITIONS

- If heating and/or air-conditioning is in operating condition, it needs to be operating. If it is not possible for the permanent heating and/or air-conditioning system to be operating before, during and after installation, a temporary heating and/or dehumidification system that mimics normal temperature and humidity conditions can enable the installation to proceed until the permanent heating system is operating.
- Moisture Testing. New concrete-type sub floors can significantly increase the relative humidity of a building, hence:
- Subfloors (wood or concrete) should be checked by an appropriate method for establishing moisture content. (See BS8201, Annex A).
- Average subfloor moisture content should be within the range as specified in Chapter 2.

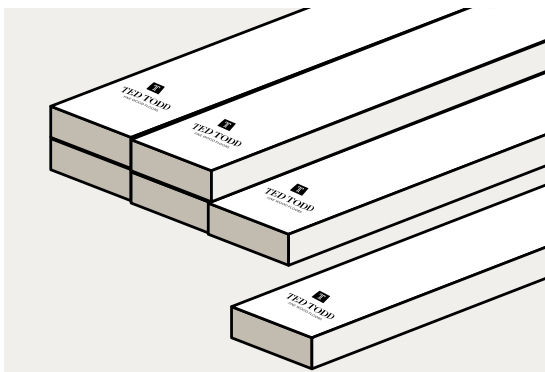

Stack Flooring packs flat on the floor

### 1A.3 Acclimatisation.

Before bringing the timber onto site ensure the requirements have been met for

- Jobsite Conditions (1.1 above)
- Moisture Testing (1.2 above and chapter 2, 16-24°C and Rh 45% to 65%)
- Ted Todd recommends that all floors are acclimatised within their packs for 2 to 3 days in the room to be installed to allow the temperature of the floor to equalize with its environment.
- Ensure that the building is enclosed with all walls, windows and doors in place.
- Verify that the building is maintained at normal living conditions for temperature and humidity. (16-24°C and Rh 45% to 65%) Where building codes allow, permanent heating and/or air-conditioning systems should be operating at least five days preceding installation to promote proper acclimatisation.
- Flooring should be stacked flat on the floor.
- If the delivery is for more than one room the order should be broken down into the individual room quantities and stored in the respective rooms.
- Extra acclimatisation may be required when using underfloor heating. See Chapter 13.



Plank



Herringbone



Chevron



Circular design panel



Continuous patterns

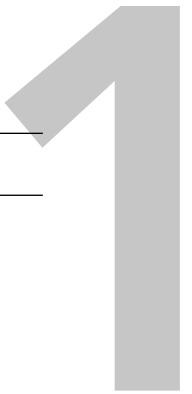

## GUIDELINES FOR: SITE CONDITIONS

### 1A.4 Installation of services (water, heating, electrical)

- Ensure any water pipes, if present in the sub floor, are at an adequate level or insulated so as not to compromise the installation and effect the timber after installation. Failure to insulate can cause localized shrinkage of the floor. Any leaks will cause expansion of the floorboards.
- Where hot water or steam pipes (other than those for underfloor heating purposes) pass under the flooring, they should be lagged or insulated to reduce localized shrinkage of the flooring in that area, and they should be fixed at a sufficient depth to avoid possible damage from fixings for the new flooring. Any insulation materials used should be able to accommodate thermal movement of pipes.
- Ensure electrical wires, if present in the sub floor, are at an adequate level to not interfere with the installation and at a sufficient depth to avoid possible damage from the fixings of the new flooring.

### 1A.5 Physical site conditions, Sub-floors and preparedness, cleanliness.

- Wood flooring ideally should be one of the last elements completed in the construction project and wood flooring should only be brought to site when the job site requirements have been met.
- Humidity and temperature conditions within the building must be 16-24°C and Rh 45% to 65%)
- Subfloors (wood or concrete) should be checked by an appropriate method for establishing moisture content. Average subfloor moisture content should be within the range as specified in Chapter 2 - Moisture Testing.
- Entrance Barrier Matting Zone. At the design stage, consideration must be given to the use of barrier matting especially in any entrances open to the outside.
- Wood shavings and other building debris should be cleaned away and prevented from accumulating under a floor as this can lead to a fire hazard.
- External Surface drainage should direct water away from the building.

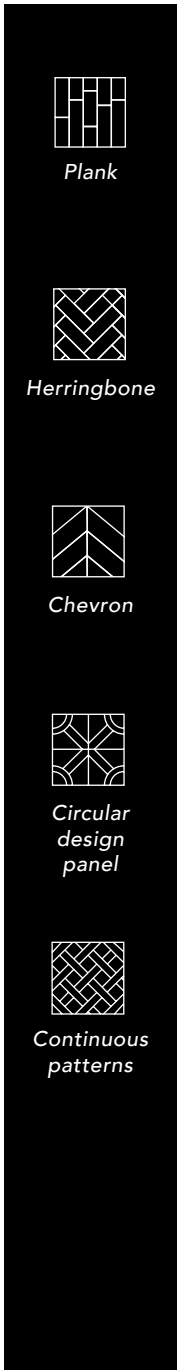

Plank



Herringbone



Chevron



Circular design panel



Continuous patterns

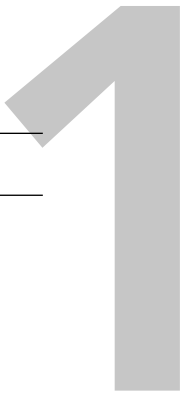

## GUIDELINES FOR: SITE CONDITIONS

- Basements and crawl spaces must be dry. If power washing is required in the basement, do so before wood flooring is installed and allow subfloor and basement to dry before installing wood flooring.
- Any crawl space should be a minimum of 457mm from ground to underside of joists.
- Crawl space earth (or thin concrete slab) should be covered 100% by a vapour barrier of polyethylene (minimum 1000 gauge) or other recommended puncture-resistant membrane. Vapour retarder joints should be well-overlapped and taped and be extended and sealed at least 150mm up the stem wall.
- When venting under a sub-floor is required. A venting area is achieved normally by using air bricks, of at least 1500mm per linear metre run of flooring should be allowed on each end to ensure adequate airflow.

**Note the ground level at the exterior of the building or any exterior feature is more than 75mm above the floor then the floor must be treated as below ground level, correct moisture barriers should be used and only engineered flooring should be installed.**

- Where the minimum jobsite conditions are present, the flooring can be delivered and stored in the rooms in which it will be installed. See section 1.3 above, Acclimatisation.

### 1A.6 Other trades.

- Do not deliver wood flooring to the jobsite or install wood flooring until all concrete, masonry, plastering, drywall, texturing and painting primer coats are completed and the humidity has been checked and within guidelines.
- If any trade work of any description is continuing on site, ensure that adequate floor protective barriers are used to prevent any damage, spills or dust reaching the surface of the wood floor.
- Plaster dust, paint and sanding dust are the biggest contaminators of finished wood floors, which are installed before all other trades are completed.

### 1A.7 Site care of your wood floor, during and after installation, and before final building handover.

- Limit floor traffic on finished flooring.
- During installation of the floor and before final handover, the installation should be checked and inspected according to BS8201-2011.
- If the floor is regularly inspected during the installation, then any potential issues may be identified and rectified rather than waiting until the installation is complete.
- Skirting or scotia may be installed and finished after the flooring installation.
- Preferably all finished wall coverings and painting should be completed before the flooring installation.

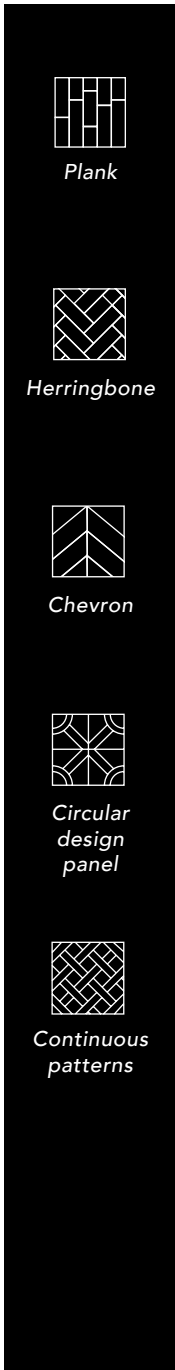

Plank



Herringbone



Chevron



Circular design panel



Continuous patterns

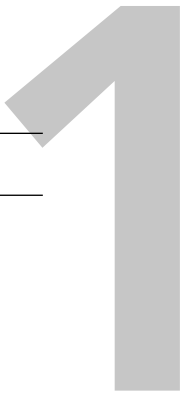

## GUIDELINES FOR: SITE CONDITIONS

- After installation, if the floor is to be protectively covered, the floor should be completely covered to prevent light-sensitive areas from changing colour.

A common, proprietary, purpose-made floor protection product, such as Correx, is a good choice. Any covering should be taped, using a low-adhesion tape, to base or skirting and taped over a wide overlap. Avoid any tape touching the finished floor surface as some adhesives may damage the floor's surface finish.

- Floors should be inspected from a normal viewing position either standing or seated. When viewing the floor, only those features which are immediately obvious to any independent party should be considered as potential issues.

**NOTE: Careful positioning of backlighting or unusual viewing angles (crouching or kneeling, etc.) would not be considered reasonable criteria for identifying a visual defect. The overall appearance of the floor should be consistent (product and installation) unless intentional as part of the product design or pattern.**

- Light-source colour can distort perceived colour / tonal variation. LED light source temperature has a big impact on perceived colour, especially sources with a temperature colour in excess of 4000K.
- Low CRI (Colour Rendering Index) light sources also distorts colour perception.
- The angle of light on the floor and surrounds can also affect appearance, e.g. between skirting and the installed floor. These factors should all be considered during inspection.

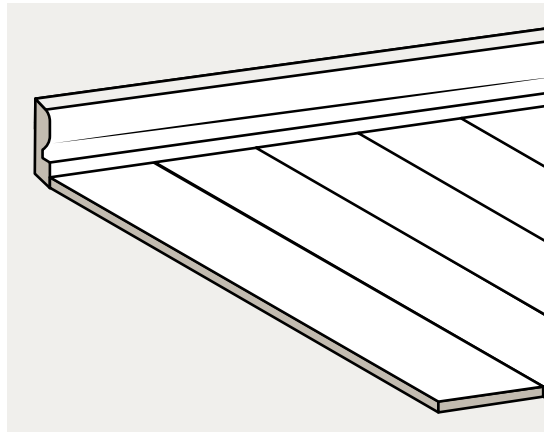

*Skirting or scotia may be installed and finished after the flooring installation.*



*Plank*



*Herringbone*



*Chevron*



*Circular design panel*



*Continuous patterns*



## GUIDELINES FOR: SITE CONDITIONS

### 1A.8 Summary.

- Check planning and integration with other trades, agree specification, site preparation to correct conditions.
- Building enclosed with windows and doors fitted.
- Other trades largely completed. Sub-floors dry. Site clean. Water, heating, power and other services installed correctly to allow wood floor installation.
- Temperature and humidity 16 to 24°C and 45% to 65% Rh. allowing correct acclimatisation
- Correct care of floor and inspection during the installation.
- Care and protection of floor after installation.



*Plank*



*Herringbone*



*Chevron*



*Circular  
design  
panel*



*Continuous  
patterns*



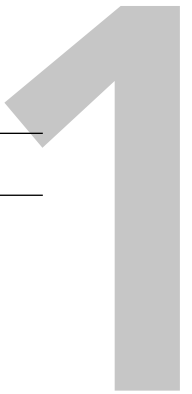

## GUIDELINES FOR: SITE CONDITIONS

### 1A.9 Frequently asked questions.

#### Is all of the above really necessary?

The success of a good wood floor installation depends upon many factors. In instances where things go wrong the problems will almost certainly be traceable back to failure to correctly follow some of the guidelines listed above. Even in apparently simple installation projects all of the above points must be checked to ensure compliance.

#### What happens if the crawl space tapers and falls below the recommended 457mm?

The most important factor is to ensure that the crawl space has adequate ventilation to prevent build up of moisture and that the underside of the wood floor is adequately protected from excessive moisture changes by a suitable moisture barrier.

#### What happens if the job-site doesn't meet the recommended conditions, e.g. if the windows aren't fitted ?

The recommendation should be to delay the arrival of the Wood Floor and don't start the work. Work together with the other trades and project manager to synchronise and re-schedule the optimum timing for when the job-site conditions will be as per the guidelines. Wood flooring can be expensive and can be damaged if the site conditions aren't correct.

#### What happens if a fault appears with the wood flooring during installation?

The installation should stop whilst the cause of the fault is identified and corrected. Always refer back to the specification of the wood floor to ensure it has been supplied correctly. Is it a visual grading issue, or specific planks of floor that are out of dimension? Maybe the site conditions (Temperature, ambient Rh and sub-floor moisture%) or sub-floor preparation are affecting the wood floor. Remember that often the cost of installing the wood floor is greater than the cost of the wood itself, so to continue an installation if something is not right is compounding any problem. Also remember that the flooring installer is the final inspector of the flooring and so any perceived defects should be identified and removed before installation and never actually installed in prominent areas of the floor.

RAS 14/06/24

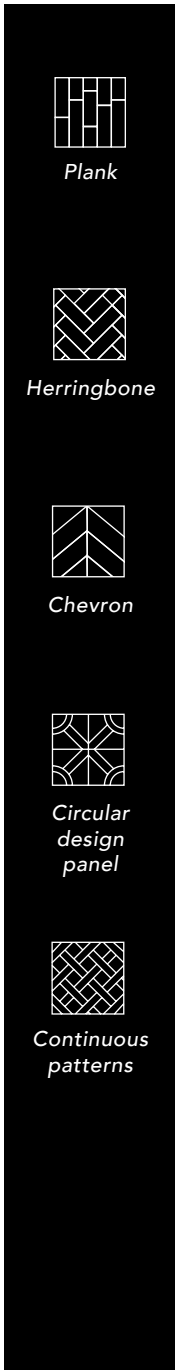

Plank



Herringbone



Chevron



Circular design panel



Continuous patterns

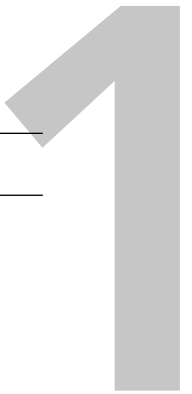

## GUIDELINES FOR: SITE CONDITIONS

### 1B.1 Site Checks

Before bringing the wood floor onto site ensure the requirements have been met for

- Jobsite Conditions (Chapter 1A)
- Moisture Testing (Chapter 1C)

### 1B.2 Acclimatisation

Ted Todd recommends that all floors are acclimatised within their packs for 2 to 3 days in the room to be installed to allow the temperature of the floor to equalize with its environment ensuring job site conditions are met.

Ensure that the building is enclosed, with all windows and external doors in place so that the internal humidity and air temperatures may be controlled correctly.

Verify that the building is maintained at normal living conditions for temperature and humidity. This should be controlled at 16-24°C and Rh 45% to 65%.

Where building codes allow, permanent heating and/or air-conditioning systems should be operating at least five days preceding installation to promote proper acclimatisation.

If it is not possible for the permanent heating and/or air-conditioning system to be operating before, during and after installation, a temporary heating and/or dehumidification system that will mimic normal temperature and humidity conditions can enable the installation to proceed until the permanent heating and/or air-conditioning system is operating.

Packs should be stacked flat on the floor.

If the delivery is for more than one room the order should be broken down into the individual room quantities and stored in the respective rooms.

Extra acclimatisation may be required when using underfloor heating. See Chapter 13.



Plank



Herringbone



Chevron



Circular design panel



Continuous patterns

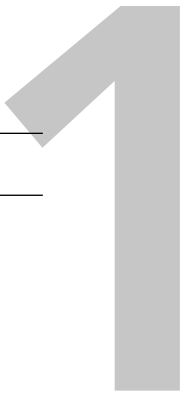

## GUIDELINES FOR: SITE CONDITIONS

### 1.B.3 FAQ's

#### Is all of the above really necessary?

The success of a good wood floor installation depends upon many factors. In instances where things go wrong, the problems will almost certainly be traceable back to failure to correctly follow some of the guidelines listed above. Even in apparently simple installation projects all of the above points must be checked to ensure compliance.

#### Why does wood flooring need acclimatisation?

Wood flooring is a natural product and a feature of this is that wood changes dimension with any change in moisture or humidity. Temperature affects the moisture content of wood and so also affects the dimensions. Wood will mainly expand across the grain as moisture increases and it also shrinks if the moisture decreases. So, for a good quality wood floor installation it is helpful if all of the wood is at the same moisture content so all of the pieces will have the same dimensions (width), and the floor can be installed without gaps opening between the pieces.

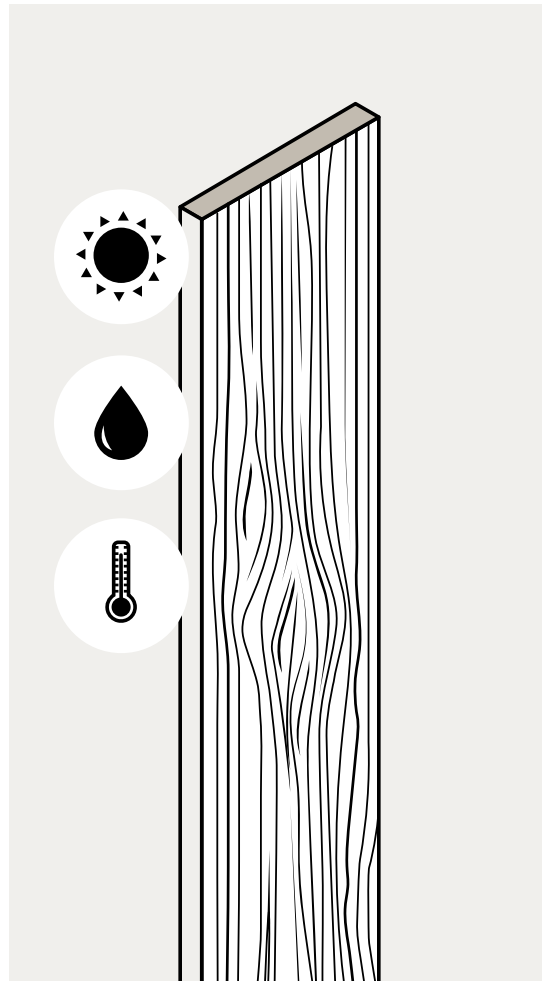

Plank



Herringbone



Chevron



Circular design panel



Continuous patterns



# GUIDELINES FOR: SITE CONDITIONS

### Below are some simple guidelines regarding sub floors and moisture testing.

Wood flooring is moisture-sensitive and so before installing wood flooring over any concrete or screeded base, it should be ensured not only that the subfloor is constructed to prevent moisture from reaching it from the ground, but also that sufficient of the water used in the construction has dissipated.

Likewise, wood flooring which is to be floated or nailed to a batten system or other wood-based subfloor should be protected from excessive relative humidity from above and below the wood floor.

It is imperative all sub floors are tested for moisture prior to bringing the flooring into the property. It is recommended that measurements are taken and recorded. They should include: the date, relative humidity, ambient temperature, type of meter, along with a plan of test locations.

**NOTE: All test give a result when completed, they give you the ability to decide whether to start the Job. In general they give you the ability to start or not start a job. These tests do not give a permanent condition of your substrate merely an "at the time the test was performed" indication.**

### Recommended moisture targets are:

- Concrete Screed should not exceed 2%
- Gypsum / Anhydrite screed should not exceed 0.5% (0.3% with underfloor heating) and always measured after removal of laitance layers.
- Wood sub floors maximum 12% and no greater than 2% of the moisture content of the wood floor.

To reduce the potential of moisture-related problems, Ted Todd recommends the use of vapour barriers with installations.

For a more comprehensive set of guidelines regarding elimination of construction moisture, please refer to BS8201- 2011, section 12.4.6 .

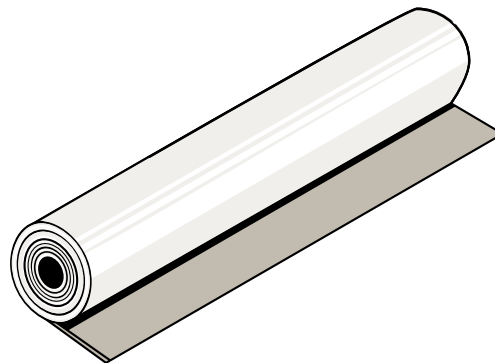

Moisture barriers are available in several types, some standalone and some built into underlay. To see the selection available visit <https://www.tedtodd.co.uk/accessories/>

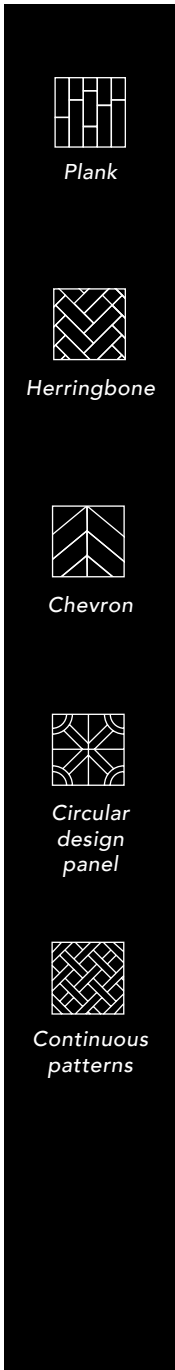

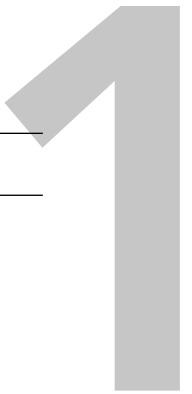

## GUIDELINES FOR: SITE CONDITIONS

### 1C.1 Wood Subfloors

Wood subfloors can take the form of wooden battens or joists to which the wood floor is usually nailed, or in a sheet format using typically OSB or plywood, to which the wood floor may be floated, glued-down or nailed down.

#### 1C.1.1 Moisture Testing of the wood subfloor.

Test for moisture using a correctly calibrated electrical resistance moisture meter, designed for wood, and operated in accordance with the manufacturer's instructions.

Test for moisture of the wood subfloor at several locations in the room, a minimum of 1 point per square meters averaging the results but paying attention to areas with any high readings. In small rooms (less than 20m<sup>2</sup>) a minimum of 5 readings should be taken.

The target moisture content of a wood subfloor should not exceed 12% or be greater than 2% of the moisture content of the floor.

A high reading in one area will indicate a problem that must be corrected. Pay special attention to exterior walls and areas of plumbing.

### 1C.1.2 Vapour Barriers for wood subfloors

For installations where the floor is to be nailed to wooden joists or battens, Ted Todd recommend using Sisalkraft 728 Builders paper as an effective vapour barrier below the floor.

For floating installations using a sheet-type wood subfloor, the vapour barrier should be made using one of the Ted Todd professional underlays with taped seams, installed between the floor and the sheet subfloor. (See chapter 4 for choice of underlay.)

For installations where the wood floor is to be glued (fully bonded) to the sheet subfloor a suitable vapour barrier or concrete primer/sealer should be installed under the sheet subfloor - 1 coat of Primerfast.

The vapour retarder underlays have some extra benefits in that they eliminate wood-on-wood contact, planks slide more easily when positioning, they minimise the impact of seasonal humidity change and may reduce dust and noise levels.



Plank



Herringbone



Chevron



Circular design panel



Continuous patterns

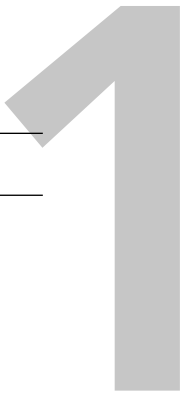

## GUIDELINES FOR: SITE CONDITIONS

### 1C.2 Concrete Slabs and Screeds

#### 1C.2.1(a) Types of Moisture tests for concrete screed

There are several types of tests for measuring the moisture content of a concrete screed:

- Electrical impedance concrete moisture meters, such as the Tramex Concrete Encounter, detects and evaluates the moisture conditions within the slab or screed by measuring the electrical impedance. This is a non-destructive, very quick, surface test.
- Calcium Carbide Test. This involves drilling a small hole in the screed and inserting a small amount of calcium carbide powder. The powder reacts with the moisture in the screed to produce acetylene gas, which is measured using a pressure gauge. This is destructive, quick and very accurate test.
- Relative Humidity Air Hygrometer Test: (NB, not to be confused with the Relative Humidity of the ambient atmosphere in the room) This is the method recommended by the British Standards. This involves the measurement of the moisture released by the screed into a sealed area over a time span of 72 hours (this is to reach equilibrium with concrete substrate). This type of test is non-destructive, slow but very accurate.
- Each test has its advantages and disadvantages. British Standards 8201:2011 recommends using Relative Humidity testing of concrete sub floors.-

However to comply with requirements set by the installation products. Ted Todd recommends testing using the Calcium Carbide method.

#### 1C.2.1(b) Types of Moisture tests for Anhydrite or Gypsum screed.

- Tests similar to those above can also apply to Anhydrite or Gypsum screeds but note it is necessary to ensure the correct calibration of the testing apparatus and the different moisture targets.

#### 1C.2.2 Moisture Testing.

Recommended moisture targets are:

- Concrete Screed should not exceed 2% MC, or 65% RH method or 75% RH if incorporating adequate vapour barrier layers.
- Gypsum / Anhydrite screed should not exceed 0.5% (0.3% with underfloor heating) and always measured after removal of laitance layers.

Before moisture testing begins, the concrete screed must be a MINIMUM of 30 days old. As a very rough guideline, for up to 40mm thickness allow drying time 1 day per 1mm of new concrete screed, (minimum 30 days) and an additional 2 days per mm above 40mm.



Plank



Herringbone



Chevron



Circular design panel



Continuous patterns

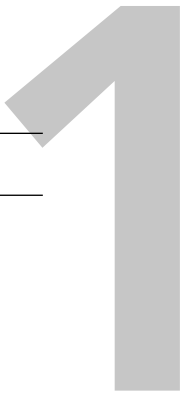

# GUIDELINES FOR: SITE CONDITIONS

For Anhydrite, Calcium Sulphate or similar screeds the guidelines as above should be followed but the laitance (the surface layer after curing) should be removed as soon as possible after curing to allow the moisture to escape. The laitance can be removed with specialist machinery by either light sanding or shot blasting.

Select test locations to provide information about moisture distribution across the entire concrete floor slab. For slabs on ground and below ground, include a test location within 1 metre of each exterior wall.

Perform ten tests for the first 93m<sup>2</sup> and one test for every additional 93m<sup>2</sup> thereafter. The actual test area should be clean and free of all foreign substances. Use approved work practices for removal of all existing flooring materials and debris.

A high reading in one area indicates a problem that must be corrected. Pay special attention to exterior walls and plumbing.

Always follow the meter manufacturer's instructions for use and ensure the correct calibration for the method and material being tested so that a reading of moisture content, by weight, of the concrete screed is obtained.

Target moisture content of concrete screed should not exceed 2%. (See 2.2.3 below ref Vapour Retarders)

If a Gypsum / Anhydrite screed is used, the target moisture content should be below 0.5%, or below 0.3% if Under Floor Heating is being used. (NB readings must be taken once any laitance layers are removed.)



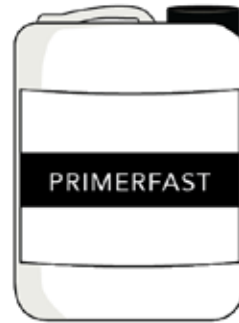

### 1C.2.3 Vapour Barriers for Concrete / Anhydrite Screeds

Ted Todd recommends using Ted Todd Primerfast liquid damp proof membrane (LDPM) prior to ALL glue-down installations (1 coat with UFH and 2 coats if no UFH). The appropriate Ted Todd professional underlay should be used for ALL floated installations. (See section 6.3.3, Floating Plank Installation, for choice of underlay)



If the calcium carbide method test gave a reading for a concrete sub floor of greater than 2% moisture reading but no more than 4%, with a 60mm thick screed or less, using Ted Todd Primer fast liquid damp proof membrane can allow you to continue with the installation. If measurements are outside of these parameters do not bring the floor onto site.

When using Ted Todd underlays all seams must be taped with either Ted Todd Aluminium Tape or the self-adhesive overlap tape where this exists.

-   
*Plank*
-   
*Herringbone*
-   
*Chevron*
-   
*Circular design panel*
-   
*Continuous patterns*



## GUIDELINES FOR: SITE CONDITIONS

Once a Gypsum/Anhydrite screed is deemed dry [usually 0.5% by the calcium carbide method, or in the case of UFH 0.3%] it is often good practice to protect the screed from moisture ingress from spillages, burst pipes, wet trades etc. In this instance and only when the screed is completely dry, the use of a liquid applied damp proof membrane (Ted Todd Primerfast) can be applied to the surface.

### 1C.3 Considerations for Vapour Barriers and moisture testing with Underfloor Heating (UFH).

For all floated installations over under floor heating (UFH) use the appropriate Ted Todd Underlay with taped seams. (See Chapter 4).

If the installation is glued-down over water fed under floor heating system, just one coat of Ted Todd Primerfast may be used if required to seal a loose screed, and to encourage better adhesion and spread of glue-down adhesive such as Ted Todd MS Flex.

**It is recommended that installations with UFH are equipped with the Ted Todd Fidbox monitoring system. This will ensure that a continuous record of the temperature and moisture conditions within the wood floor can be obtained.**

### 1C.4 Summary

- Check the MC of the subfloors before bringing wood flooring onto site.
- No more than 2% MC or 65% RH for concrete screeds, but up to 4% MC and 75% RH with certain installations with adequate vapour barriers.
- No more than 0.5% for anhydrite screeds. (0.3% with UFH)
- Always use a suitable vapour barrier, correctly installed with regard to the installation method for the wood floor and with regard to the type of subfloor.
- The use of a Fidbox monitoring system is recommended for wood floor installations over UFH.



Plank



Herringbone



Chevron



Circular design panel



Continuous patterns



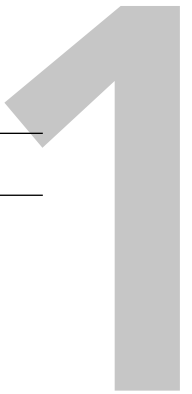

## GUIDELINES FOR: SITE CONDITIONS

### 1C.5. FAQ's

#### Is all of the above really necessary?

The success of a good wood floor installation depends upon many factors. In instances where things go wrong the problems will almost certainly be traceable back to failure to correctly follow some of the guidelines listed above. Even in apparently simple installation projects all of the above points must be checked to ensure compliance.

#### Why must I measure my subfloor moisture levels?

Wood floors can be damaged if they absorb too much moisture. The wood will expand across its width if it becomes too wet and this can cause buckling, cupping, lipping and even delamination of the floorboards. Even when dry to the touch, concrete subfloors may still be too wet to allow a successful wood floor installation. Hence the need to accurately measure the moisture content of the subfloor.

New, thick concrete screeds will take many months to dry out properly. Older buildings may suffer from leaks, damp and inadequate ventilation causing excessive moisture patches in certain areas of the floor.

#### Can I use my wood moisture meter to measure the concrete's moisture ?

No. Not normally. Moisture meters work by measuring the electrical resistance of the material being tested. Wood and concrete have very different characteristics and so the measuring meters are not usually interchangeable. Wood moisture meters even need to be calibrated correctly for the timber species being measured and so using a wood moisture meter on a non wood-based material will not work.

#### Are vapour barriers just to keep out moisture from reaching the wood floor?

There are other advantages to using vapour barriers. Many of the Ted Todd underlays also provide thermal insulation, sound insulation – both transmitted and reflected- and can make the installation of the wood easier by allowing the boards to slide together more easily.

The Ted Todd Primerfast liquid damp proof membrane (LDPM) when applied to a concrete screed for a glue-down installation will not only form a vapour barrier but also help the adhesion between the MS Flex adhesive and the subfloor.

RAS 14/05/24



Plank



Herringbone



Chevron



Circular design panel



Continuous patterns