



# TED TODD

FINE WOOD FLOORS

## INSTALLATION GUIDE



*Plank*



*Narrow  
Plank*



*Wide  
Plank*



*Extra-Wide  
Plank*



*Super-Wide  
Plank*



*Herringbone*



*Chevron*



*Chantilly  
panel*



*Parquet de  
Versailles*



*Parquet de  
Chevney*



*Circular  
design panel*



*Parquet de  
Ardeche*



*8 tile  
parquet de  
versailles*



*Shrawley*



*Avery*



*Continuous  
Versailles*



*Wall  
Cladding*



## INSTALLATION OF: PLANKS - NAILED DOWN

There are 3 main methods for installing Ted Todd wood floor planks.

- Fully-Bonded (Glued down)
- Floating
- Nailed down
- Decide very early in the project what is the preferred installation method with due regard to the subfloor, the type of wood floor being installed and the end-use of the area of installation.
- Always check with the end-user that the correct product has been delivered and that they are happy with the grade and visual appearance of the floor. Open several packs at a time and mix the boards to ensure a good degree of board selection so the installation is visually well-balanced.
- Agree on the laying pattern and the orientation of the planks within each room. Normally the longest run of the room is the direction the planks should be laid, but do consider other factors such as lighting, windows and doors.
- Agree on the width balance of the planks in the room too.
- All installations should comply with BS8201.

### 6.1 Site Checks

Before commencing installation ensure the requirements have been met for:

- Jobsite Conditions, Moisture Testing and Acclimatisation (Chapter 1A, 1B and 1C).
- Ambient temperature range of 16 to 24°C.
- Ambient relative humidity of RH of 45 to 65%
- Subfloors, see Chapter 2 for a full check list.

### 6.2 Acceptable Sub Floors

- Wood-based panels, such as OSB, Plywood, Chipboard. Moisture content no more than 12% and no more than 2% difference with the wood floor.
- Concrete / Screed. For concrete screeds moisture content should not exceed 2% (calcium carbide measure) or RH of 65%. Anhydrite-based screeds with MC of no more than 0.5% (0.3% with UFH).
- Joists - 20mm products only. Always use a Sisalkraft type Builders Paper as a moisture barrier.
- Tiles – when flat.
- Subfloors must be Dry and Flat. See Chapter 2.



Narrow Plank



Plank



Wide Plank



Extra-Wide Plank



Super-Wide Plank

## INSTALLATION OF: PLANKS - NAILED DOWN

### 6.3 Installation Guidelines, All Planks installations.

Choose a starting wall according to the most aesthetically or architecturally important elements in the room, taking into consideration fireplaces, doors, cabinets and transitions, as well as the squareness of the room. The starting wall will often be the longest unbroken wall in the room but do consider all other factors such as lighting. Do consider the width balance of the planks across the room too.

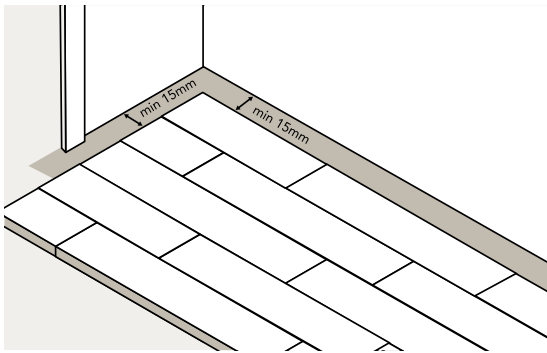

Figure 1: Leave a minimum of 15mm around the perimeter and all architectural details and obstructions

Where possible, expansion gaps must be left though doorways/archways and covered with T-sections to break up large areas of installation. A minimum expansion space of 15mm must be left around the perimeter and all vertical obstructions.

Remember that the floor must be allowed to expand and contract under the thresholds, skirting and other joint covers.

Door architraves can be undercut to allow for the floor planks to fit underneath and still permit the expansion and contraction of the planks.

Consider how the perimeter expansion gaps will be covered after installation. Skirting boards or scotia and other profiled shapes are available for this. They must be installed to allow for movement of the flooring planks below.

Plan to distribute lengths of planks in a fashion where the end joints are randomly staggered. Avoid "H" patterns (as below) and other discernible patterns in adjacent runs. Stagger end joints at least three times the width of the boards, as product allows.

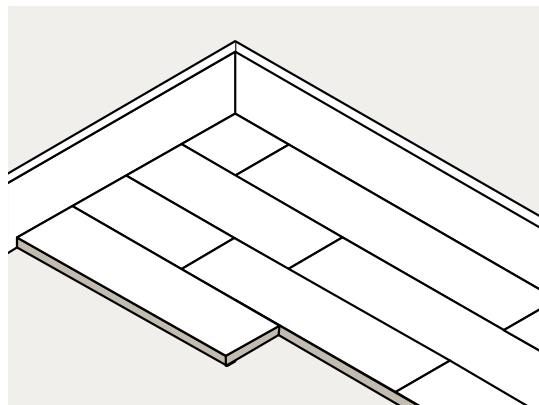

Figure 2: shows a typical arrangement of planks, using one offcut to start a row and the other to finish.



Narrow Plank



Plank



Wide Plank



Extra-Wide Plank



Super-Wide Plank



## INSTALLATION OF: PLANKS - NAILED DOWN

Use the offcut from the end of one row to start the next row.

Consider the width balance of the planks across the room. Plan ahead to ensure that opposite walls have approximately half-width planks to avoid narrow off-cuts which are difficult to install and can look odd.

For 2 and 3-layer engineered flooring there is frequently a bow within the board. This can be up to 1.5% of the board length and therefore it is important to ensure that the first rows are laid with the boards being interlocked to around half of the length. This will ensure the boards lie flat and permit installation.

### 6.4 Installation Guidelines, Ted Todd Planks.

#### Nail Down Method.

The advantages of this more-traditional method include faster installation by experienced crafts persons and in some cases lower installation costs. Some clients also prefer the feel look and sound of a nailed down floor. Nail down is often the best method if using solid hardwood flooring planks.

Ted Todd Plank floors can be nailed down or screwed to either wooden joists or battens, or to wood-based panel products such as 12mm plywood. Chipboard and OSB may also be used as a subfloor with minimum thickness of 18mm when used with suitable tongue screws.

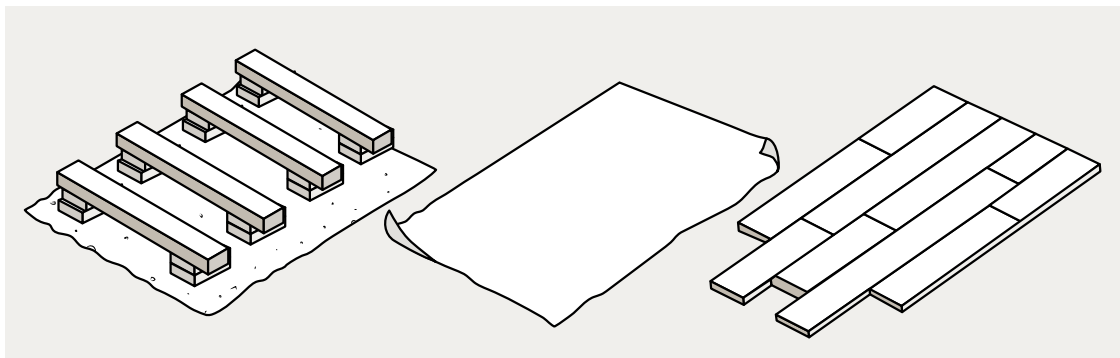

Figure 3: subfloor, joists, Siza kraft builders paper, wood floor planks



Narrow Plank



Plank



Wide Plank



Extra-Wide Plank



Super-Wide Plank



## INSTALLATION OF: PLANKS - NAILED DOWN

**For planks in excess of 250mm width it is recommended that a glue down (fully bonded) installation method be used. This is because with very wide planks, the number of nail fixings per m2 of flooring will be much lower than with narrower width planks.**

If Ted Todd Plank floors are to be nailed down directly to existing wood floorboards, the flooring planks must be laid at 90 degrees or 45 degrees to the floorboards below. Alternatively add a layer of 12mm plywood to the existing wood floorboards.

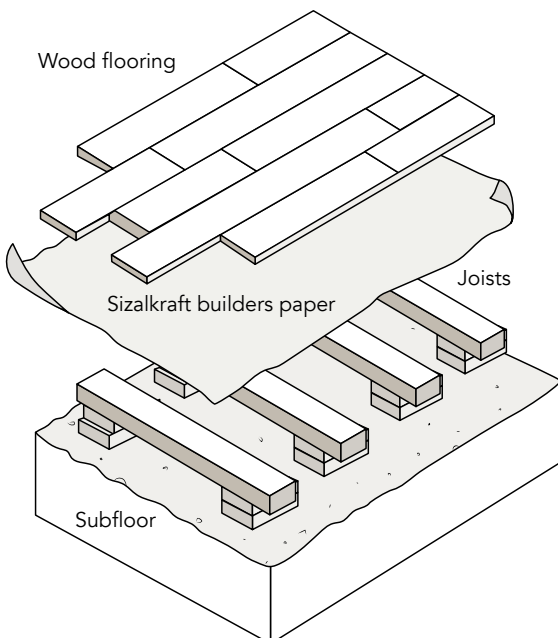
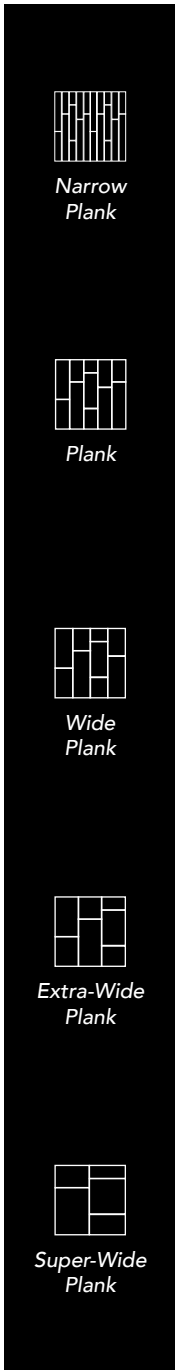

Figure 4: A typical nail down installation

Nail down installations are not recommended for installations with UFH. (See Chapters 13 for additional guidelines for installations with UFH).

### 6.4.1 Laying out and getting started.

- When nailing Ted Todd Planks to joists, always use a Sisalkraft Builders Paper. Overlap any seams by 100mm and return the edges up the wall to act as a moisture barrier. The floor planks should be nailed through the bitumen Builders Paper.
- When nailing to timber joists or battens, planks must be of a structural rating so, only use those Ted Todd Planks with a minimum thickness exceeding 18mm. Batten or joist centres must comply with local building regulations and depends upon the type of flooring being installed and the end use of the room / building.
- It is recommended to use a commercially available nail gun, either a manually driven nailer, or a pneumatic-type nailer. Always use nails specified for use with T&G flooring, so that the head of the nail will sit "secretly" within the nail pocket of the flooring planks and won't inhibit the joining of the next board. Nails should be at least 2.5 times the thickness of the flooring planks.
- The planks should be secret nailed through the tongue. It may be necessary on the first or last rows to top-nail, or nail through the groove to ensure the first and last rows sit tightly.



## INSTALLATION OF: PLANKS - NAILED DOWN

- Following the guidelines in 3.0 to 3.3 above start laying out the planks on top of the subfloor, joists or underlay.
- Snap a working line parallel to the starting wall, the width of the board, plus the tongue and recommended expansion space.
- Use Spacers between the wall and the first row of flooring planks allowing for any taper or unevenness in the wall. This helps maintain the correct expansion gap and allows for the first row to be supported when installing or knocking together the T&G of following rows.
- Work by starting with the T&G groove nearest the wall and the tongue facing outwards.
- Secret nail the first row (hand-nail if necessary), using appropriate fasteners. Denser species may require pre-drilling. Each succeeding row should be secret-nailed through the tongue, at intervals wherever possible:
  - a. Joists / batten sub floors – Secret nail in each joist;
  - b. Plank or Panel sub floors – Nail every 200 – 300mm.
- Take care when nailing close (within 50mm) to the end of each board to avoid splitting the tongue.
- All Ted Todd Plank floors over 18mm are ends matched. When installing over joists or battens at 450mm centres there is no requirement to support head joints on a joist for normal domestic installations. If heavier point loading is expected all header joints should be supported by cutting the end-joint to align over a joist or batten.

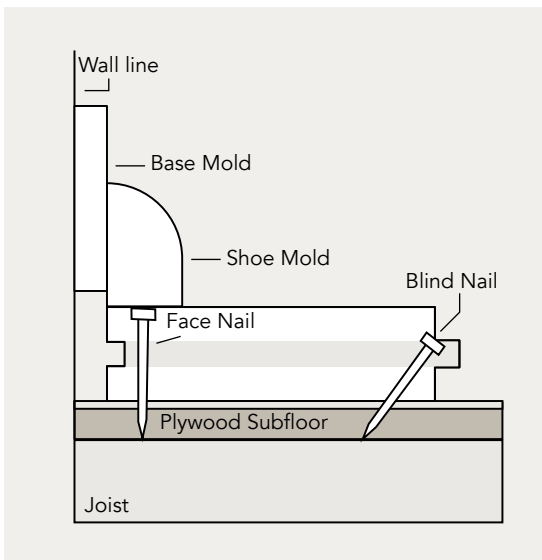

Figure 5: An example of a secret nailed floor.



Narrow Plank



Plank



Wide Plank



Extra-Wide Plank



Super-Wide Plank



## INSTALLATION OF: PLANKS - NAILED DOWN

### 6.5 Summary

- Site checks, site ready for wood floor
- Temperature and humidity
- Subfloor and joists / battens correctly prepared, clean, dry, flat and level.
- Minimum thickness of 18mm when installed over joists or battens.
- Always use Sisalkraft Builders Paper as a moisture barrier when installing over joists.

### 6.6 Frequently Asked Questions

#### Is all of the above really necessary?

The success of a good wood floor installation depends upon many factors. In instances where things go wrong, the problems will almost certainly be traceable back to failure to correctly follow some of the guidelines listed above. Even in apparently simple installation projects all of the above points must be checked to ensure compliance.

#### What is the advantage of a nail-down installation?

Nail down is the traditional way of fixing down a wood floor. It is often faster and cheaper to install than more modern methods such as glue down or floating.



Narrow Plank



Plank



Wide Plank



Extra-Wide Plank



Super-Wide Plank